



# MASTER LEDspot LV

## MASTER LED 6.5-50W 940 MR16 24D Dim

Delivering intense accent beam, MASTER LEDspot LV is an ideal retrofit solution for spot lighting. MASTER LEDspot LV is designed to replace halogen or incandescent spots. It realizes natural colors, enables cozy and comfortable ambience for residential, hospitality and emphasizes the beauty of merchandise in retail. New smaller housing provides perfect fitting with majority of luminaires in a market with a MR16 GU 5.3 holder. It not only employs Philips' patented solution to guarantee the broadest possible compatibility with standard 12V halogen electronic transformers, it also delivers high beam intensity which is equivalent to halogen MR16 spots. The dimming function enables to create the desired atmosphere and it works with broad selection of dimmers. Its high SDCM ensure stricter color consistency, that is maintained over product life. MASTER LEDspot LV delivers huge energy savings and minimizes maintenance cost without any compromise on light quality and lifetime, enabling residential and business owners to achieve a return on their investment within short period time.

### Product data

General Information	
Cap-Base	GU5.3
Nominal lifetime	40,000 hour(s)
Switching Cycle	50,000
Lighting Technology	LED

Light Technical	
Color Code	940 [CCT of 4000K]
Beam Angle (Nom)	24 degree(s)
Luminous Flux	530 lm
Luminous Intensity (Nom)	3,400 cd
Color Designation	Cool White (CW)
Correlated Color Temperature (Nom)	4000 K

Operating and Electrical	
Luminous Efficacy (rated) (Nom)	81.00 lm/W
Color Consistency	<4
Color rendering index (CRI)	90
LLMF At End Of Nominal Lifetime (Nom)	70 %
Line Frequency	- Hz
Input Frequency	- Hz
Power Consumption	6.5 W
Lamp Current (Nom)	650 mA
Wattage Equivalent	50 W
Starting Time (Nom)	0.5 s
Warm-up time to 60% light	0.5 s

# MASTER LEDspot LV

Power Factor (Fraction)	0.7
Voltage (Nom)	ac electronic 12 V

## Temperature

T-Case Maximum (Nom)	90 °C
----------------------	-------

## Controls and Dimming

Dimmable	Only with specific dimmers
----------	----------------------------

## Mechanical and Housing

Bulb Shape	MR16
Net Weight (Piece)	0.060 kg

## Approval and Application

Suitable For Accent Lighting	Yes
------------------------------	-----

EU RoHS compliant	Yes
-------------------	-----

## Product Data

Order product name	MASTER LED 6.5-50W 940 MR16 24D Dim
Full product name	MASTER LED 6.5-50W 940 MR16 24D Dim
Full product code	871951435783900
Order code	929003072108
Material Nr. (12NC)	929003072108
Numerator - Quantity Per Pack	1
EAN/UPC - Product/Case	8719514357839
Numerator - Packs per outer box	10
EAN/UPC - Case	8719514357846

## Dimensional drawing

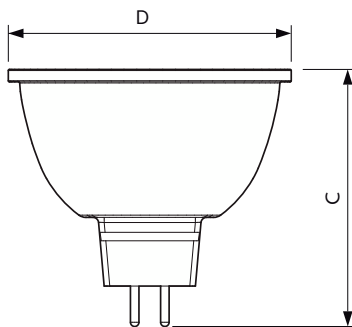

Product	D	C
MASTER LED 6.5-50W 940 MR16 24D Dim	50 mm	46.5 mm

## Photometric data

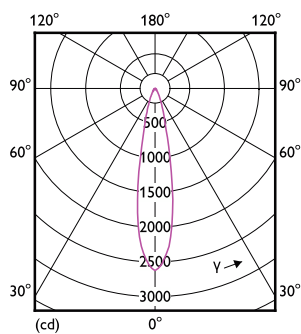
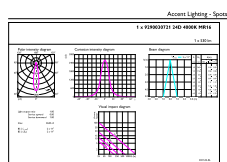

Accent Lighting Spots - MASTER LED 6.5-50W 940 MR16 24D Dim

Light Distribution Diagram - MASTER LED 6.5-50W 940 MR16 24D Dim

# MASTER LEDspot LV

## Photometric data

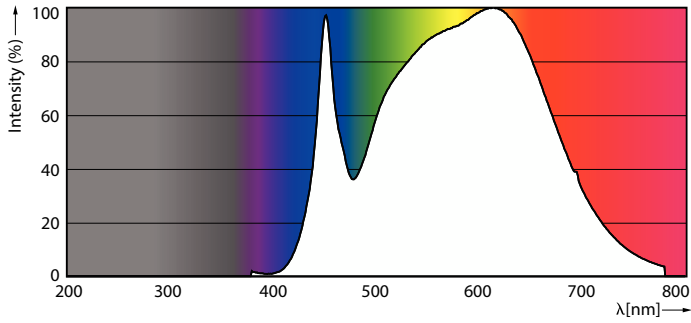

Spectral Power Distribution Colour - MASTER LED 6.5-50W 940 MR16 24D Dim

## Lifetime



Life Expectancy Diagram



Lumen Maintenance Diagram - MASTER LED 6.5-50W 940 MR16 24D Dim

