



MASTER LEDspot LV

MASTER LED 6.5-50W 930 MR16 24D Dim

Delivering intense accent beam, MASTER LEDspot LV is an ideal retrofit solution for spot lighting. MASTER LEDspot LV is designed to replace halogen or incandescent spots. It realizes natural colors, enables cozy and comfortable ambience for residential, hospitality and emphasizes the beauty of merchandise in retail. New smaller housing provides perfect fitting with majority of luminaires in a market with a MR16 GU 5.3 holder. It not only employs Philips' patented solution to guarantee the broadest possible compatibility with standard 12V halogen electronic transformers, it also delivers high beam intensity which is equivalent to halogen MR16 spots. The dimming function enables to create the desired atmosphere and it works with broad selection of dimmers. Its high SDCM ensure stricter color consistency, that is maintained over product life. MASTER LEDspot LV delivers huge energy savings and minimizes maintenance cost without any compromise on light quality and lifetime, enabling residential and business owners to achieve a return on their investment within short period time.

Product data

General Information		Operating and Electrical	
Cap-Base	GU5.3	Luminous Efficacy (rated) (Nom)	76.00 lm/W
Nominal lifetime	40,000 hour(s)	Color Consistency	<4
Switching Cycle	50,000	Color rendering index (CRI)	90
Lighting Technology	LED	LLMF At End Of Nominal Lifetime (Nom)	70 %
Light Technical		Line Frequency	- Hz
Color Code	930 [CCT of 3000K]	Input Frequency	- Hz
Beam Angle (Nom)	24 degree(s)	Power Consumption	6.5 W
Luminous Flux	500 lm	Lamp Current (Nom)	650 mA
Luminous Intensity (Nom)	2,800 cd	Wattage Equivalent	50 W
Color Designation	White (WH)	Starting Time (Nom)	0.5 s
Correlated Color Temperature (Nom)	3000 K	Warm-up time to 60% light	0.5 s

MASTER LEDspot LV

Power Factor (Fraction)	0.7
Voltage (Nom)	ac electronic 12 V
Temperature	
T-Case Maximum (Nom)	90 °C
Controls and Dimming	
Dimmable	Only with specific dimmers
Mechanical and Housing	
Bulb Shape	MR16
Net Weight (Piece)	0.060 kg
Approval and Application	
Suitable For Accent Lighting	Yes

EU RoHS compliant	Yes
Product Data	
Order product name	MASTER LED 6.5-50W 930 MR16 24D Dim
Full product name	MASTER LED 6.5-50W 930 MR16 24D Dim
Full product code	871951435779200
Order code	929003072008
Material Nr. (12NC)	929003072008
Numerator - Quantity Per Pack	1
EAN/UPC - Product/Case	8719514357792
Numerator - Packs per outer box	10
EAN/UPC - Case	8719514357808

Dimensional drawing

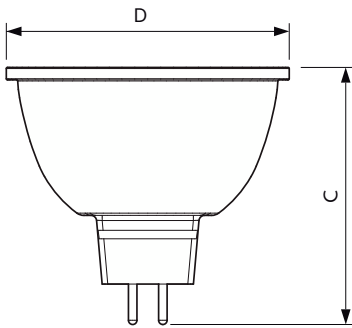

Product	D	C
MASTER LED 6.5-50W 930 MR16 24D Dim	50 mm	46.5 mm

Photometric data

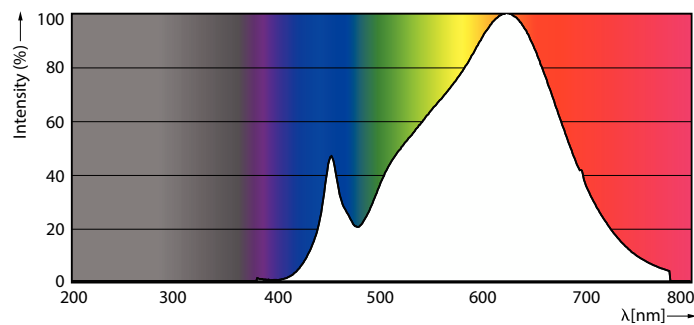

Spectral Power Distribution Colour - MASTER LED 6.5-50W 930 MR16 24D Dim

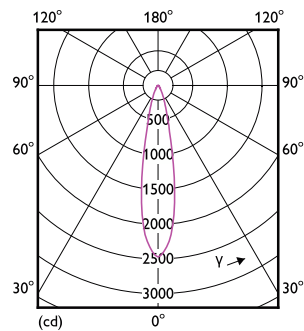

Light Distribution Diagram - MASTER LED 6.5-50W 930 MR16 24D Dim

MASTER LEDspot LV

Photometric data

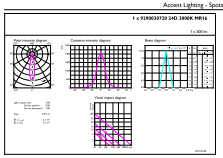

Accent Lighting Spots - MASTER LED 6.5-50W 930 MR16 24D Dim

Lifetime

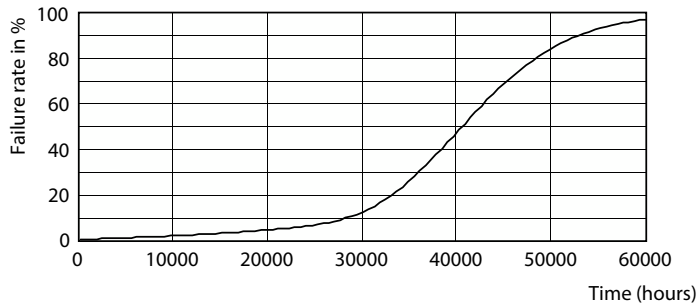

Life Expectancy Diagram

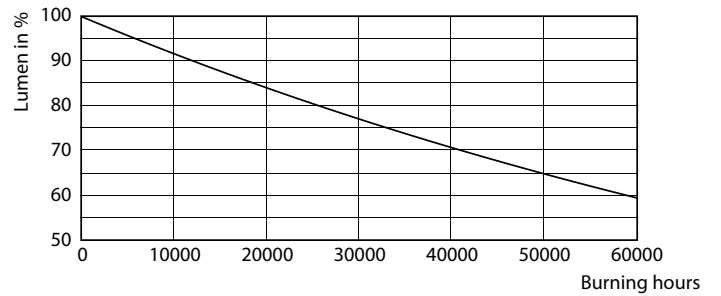

Lumen Maintenance Diagram - MASTER LED 6.5-50W 930 MR16 24D Dim

